

The BLAIN EV program includes the widest range of options offered to the elevator industry for high performance passenger service. Easy to install, EV's are smooth, reliable and precise in operation throughout extreme load and temperature variations.



Description

Available port sizes are 3/4", 1 1/2", 2" and 2 1/2" pipe threads, depending on flow. EV's start on less than minimum load and can be used for across the line or wye-delta starting. According to customers' information, valves are factory adjusted ready for operation and very simple to readjust if so desired. The patented up levelling system combined with compensated pilot control ensure stability of elevator operation and accuracy of stopping independent of wide temperature variations.

EV valves include the following features essential to efficient installation and trouble free service:



- Simple Responsive Adjustment
- Temperature and Pressure Compensation
- Solenoid with Connecting Cables
- Pressure Gauge and Shut Off Cock
- Self Closing Manual Lowering

- Self Cleaning Pilot Line Filters
- Self Cleaning Main Line Filter (Z-T)
- Built-in Turbulence Suppressors
- 70 HRC Rockwell Hardened Bore Surfaces
- 100% Continuous Duty Solenoids

Technical Data:		3/4" EV	1 1/2" & 2" EV	2 1/2" EV
Flow Range:	l/min	10-125 (2-33 US gpm)	30-800 (8-211 US gpm)	500-1530 (132-404 US gpm)
Pressure Range (valve):	bar	8-100 (116-1450 psi)	8-100 (116-1450 psi)	8-68 (116-986 psi)
Press. Range CSA (valve):	bar	8-100 (116-1450 psi)	8-70 (116-1015 psi)	8-47 (116-682 psi)
Burst Pressure Z:	bar	575 (8339 psi)	505 (7324 psi)	340 (4931 psi)
Pressure Drop P-Z:	bar	6 (87 psi) at 125 l/min	4 (58 psi) at 800 l/min	4 (58 psi) at 1530 l/min
Weight:	kg	5 (11 lbs)	10 (22 lbs)	14 (31 lbs)
Oil Viscosity:	25-60 cSt. at 40°C (104°F).			
Solenoids AC:	24 V/1.8 A, 42 V/1.0 A, 110 V/0.43 A, 230 V/0.18 A, 50/60 Hz.			
Solenoids DC:	12 V/2.0 A, 24 V/1.1 A, 42 V/0.5 A, 48 V/0.6 A, 80 V/0.3 A, 110 V/0.25 A, 196 V/0.14 A.			
				Max. Oil Temperature: 70°C (158°F) Insulation Class, AC and DC: IP 68

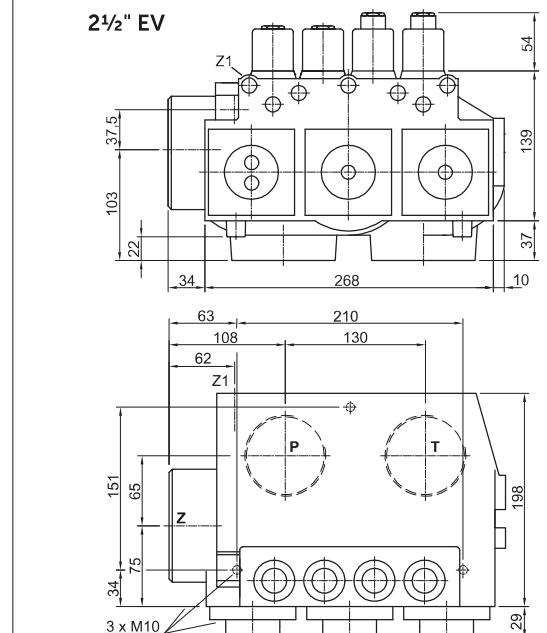
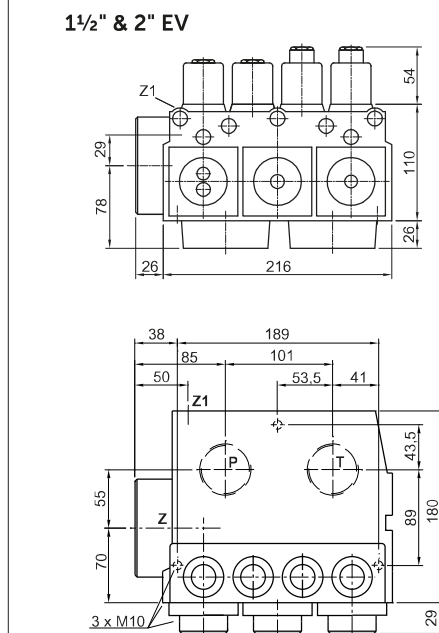
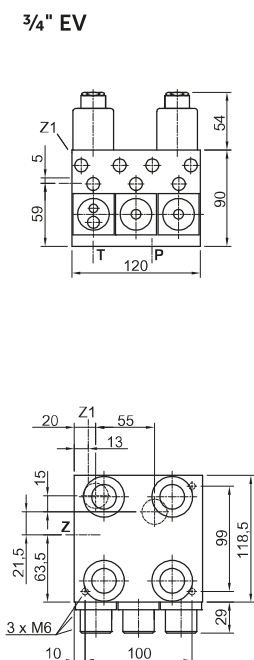

Blain Hydraulics GmbH
Pfaffenstrasse 1
74078 Heilbronn
Germany

Tel. +49 7131 28210
Fax +49 7131 282199
www.blain.de
info@blain.de



GmbH

Designer and Manufacturer of the highest quality control valves & safety components for hydraulic elevators



EV Control Valve Types

Optional Equipment

EN	Emergency Power Solenoid	DH	High Pressure Switch
CSA	CSA Solenoids	DL	Low Pressure Switch
KS	Slack Rope Valve	CX	Pressure Compensated Down
BV	Main Shut-Off Valve	MX	Auxiliary Down
HP	Hand Pump		

EV 0

3/4"



1 1/2" & 2" EV



2 1/2"



- Up** Up to 0.16 m/s (32 fpm). 1 Up Speed.
Up Start is smooth and adjustable.
Up Stop by de-energising the pump-motor.
- Down** Up to 1.0 m/s (200 fpm). 1 Full Speed and 1 Levelling Speed.
All down functions are smooth and adjustable.

USA Patent No. 4,601,366
Pats & Pats Pend: France, Germany, Italy, Japan, Switzerland & U.K.

EV 1



- Up** Up to 0.16 m/s (32 fpm). 1 Up Speed.
Up to 0.4 m/s (80 fpm) by overtravelling and levelling back down.
Up Start is smooth and adjustable.
Up Stop is smooth and exact through valve operation whereby the pump must run approx. 1 sec. longer through a time relay.
- Down** Up to 1.0 m/s (200 fpm). 1 Full Speed and 1 Levelling Speed.
All down functions are smooth and adjustable.

USA Patent No. 4,601,366
Pats & Pats Pend: France, Germany, Italy, Japan, Switzerland & U.K.

EV 10



- Up** Up to 1.0 m/s (200 fpm). 1 Full Speed and 1 Levelling Speed.
Up Start and Slow Down are smooth and adjustable.
Up Levelling speed is adjustable.
Up Stop is by de-energising the pump-motor.
- Down** Up to 1.0 m/s (200 fpm). 1 Full Speed and 1 Levelling Speed.
All down functions are smooth and adjustable.

USA Patent No. 4,637,495
Pats & Pats Pend: France, Germany, Italy, Japan, Switzerland & U.K.

EV 100



- Up** Up to 1.0 m/s (200 fpm). 1 Full Speed and 1 Levelling Speed.
All 'up' functions are smooth and adjustable.
Up Levelling speed is adjustable.
Up Stop is smooth and exact through valve operation whereby the pump must run approx. 1 sec. longer through a time relay.
- Down** Up to 1.0 m/s (200 fpm). 1 Full Speed and 1 Levelling Speed.
All down functions are smooth and adjustable.

USA Patent No. 4,637,495
Pats & Pats Pend: France, Germany, Italy, Japan, Switzerland & U.K.



Warning: Only qualified personnel should adjust or service valves. Unauthorised manipulation may result in injury, loss of life or damage to equipment. Prior to servicing internal parts, ensure that the electrical power is switched off, cylinder line is closed and residual pressure in the valve is reduced to zero.



Adjustments UP

Valves are already adjusted and tested. Check electrical operation before changing valve settings. Test that the correct solenoid is energised, by removing nut and raising solenoid slightly to feel pull.

Nominal Settings: Adjustments **1 & 4** approx. level with flange faces. Up to two turns in either direction may then be necessary. Adjustments **2, 3 & 5** all the way 'in' (clockwise) then two turns 'out' (c-clockwise). A small final adjustment may be necessary.

- EV 0**
- 1. By Pass:** When the pump is started, the unloaded car should remain stationary at the floor for a period of 1 to 2 seconds before starting upwards. The length of this delay is determined by the setting of adjustment **1**. 'In' (clockwise) shortens the delay, 'out' (c-clockwise) lengthens the delay.
 - 2. Up Acceleration:** With the pump running, the car will accelerate according to the setting of adjustment **2**. 'In' (clockwise) provides a softer acceleration, 'out' (c-clockwise) a quicker acceleration.
Up Stop: The pump-motor is de-energised. There is no adjustment.
Alternative Up Stop with Over-travel: The motor is de-energised at floor level. Through the flywheelaction of the pump-motor drive the car will travel to just above floor level. In overtravelling the floor, down levelling solenoid **D** is energised, lowering the car smoothly back down to floor level where **D** is de-energised.
- S Relief Valve:** 'In' (clockwise) produces a higher, 'out' (c-clockwise) a lower maximum pressure setting. After turning 'out', open manual lowering **H** for an instant.
Important: When testing relief valve, close ball valve gradually.

- EV 1**
- 1. By Pass:** When the pump is started and solenoid **A** energised, the unloaded car should remain stationary at the floor for a period of 1 to 2 seconds before starting upwards. The length of this delay is determined by the setting of adjustment **1**. 'In' (clockwise) shortens the delay, 'out' (c-clockwise) lengthens the delay.
 - 2. Up Acceleration:** With the pump running and solenoid **A** energised as in 1, the car will accelerate according to the setting of adjustment **2**. 'In' (clockwise) provides a softer acceleration, 'out' (c-clockwise) a quicker acceleration.
 - 5. Up Stop:** At floor level, solenoid **A** is de-energised. Through a time relay the pump should run approx. 1 second longer to allow the car to stop smoothly by valve operation according to the setting of adjustment **5**. 'In' (clockwise) provides a softer stop, 'out' (c-clockwise) a quicker stop.
Alternative Up Stop: At relatively higher speeds, the car will travel to just above floor level. In overtravelling the floor, down levelling solenoid **D** is energised, lowering the car smoothly back down to floor level where **D** is de-energised.
- S Relief Valve:** 'In' (clockwise) produces a higher, 'out' (c-clockwise) a lower maximum pressure setting. After turning 'out', open manual lowering **H** for an instant.
Important: When testing relief valve, close ball valve gradually.

- EV 10**
- 1. By Pass:** When the pump is started and solenoid **B** energised, the unloaded car should remain stationary at the floor for a period of 1 to 2 seconds before starting upwards. The length of this delay is determined by the setting of adjustment **1**. 'In' (clockwise) shortens the delay, 'out' (c-clockwise) lengthens the delay.
 - 2. Up Acceleration:** With the pump running and solenoid **B** energised as in 1, the car will accelerate according to the setting of adjustment **2**. 'In' (clockwise) provides a softer acceleration, 'out' (c-clockwise) a quicker acceleration.
 - 3. Up Deceleration:** When solenoid **B** is de-energised, the car will decelerate according to the setting of adjustment **3**. **'In' (clockwise) provides a softer deceleration, 'out' (c-clockwise) a quicker deceleration.**
 - 4. Up Levelling:** With solenoid **B** de-energised as in 3, the car will proceed at its levelling speed according to the setting of adjustment **4**. 'In' (clockwise) provides a slower, 'out' (c-clockwise) a faster up levelling.
Up stop: The pump-motor is de-energised. There is no adjustment.
- S Relief Valve:** 'In' (clockwise) produces a higher, 'out' (c-clockwise) a lower maximum pressure setting. After turning 'out', open manual lowering **H** for an instant.
Important: When testing relief valve, close ball valve gradually.

- EV 100**
- 1. By Pass:** When the pump is started, and solenoids **A** and **B** energised, the unloaded car should remain stationary at the floor for a period of 1 to 2 seconds before starting upwards. The length of this delay is determined by the setting of adjustment **1**. 'In' (clockwise) shortens the delay, 'out' (c-clockwise) lengthens the delay.
 - 2. Up Acceleration:** With the pump running and solenoids **A** and **B** energised as in 1, the car will accelerate according to the setting of adjustment **2**. 'In' (clockwise) provides a softer acceleration, 'out' (c-clockwise) a quicker acceleration.
 - 3. Up Deceleration:** When solenoid **B** is de-energised, whilst solenoid **A** remains energised, the car will decelerate according to the setting of adjustment **3**. 'In' (clockwise) provides a softer deceleration, 'out' (c-clockwise) a quicker deceleration.
 - 4. Up Levelling:** With solenoid **A** energised and solenoid **B** de-energised as in 3., the car will proceed at its levelling speed according to the setting of adjustment **4**. 'In' (clockwise) provides a slower, 'out' (c-clockwise) a faster up levelling.
 - 5. Up Stop:** At floor level, solenoid **A** is de-energised with solenoid **B** remaining de-energised. Through a time relay the pump should run approx. 1 second longer to allow the car to stop smoothly by valve operation according to the setting of adjustment **5**. 'In' (clockwise) provides a softer stop, 'out' (c-clockwise) a quicker stop.
- S Relief Valve:** 'In' (clockwise) produces a higher, 'out' (c-clockwise) a lower maximum pressure setting. After turning 'out', open manual lowering **H** for an instant.
Important: When testing relief valve, close ball valve gradually.



Warning: Only qualified personnel should adjust or service valves. Unauthorised manipulation may result in injury, loss of life or damage to equipment. Prior to servicing internal parts, ensure that the electrical power is switched off, cylinder line is closed and residual pressure in the valve is reduced to zero.



Adjustments DOWN

Valves are already adjusted and tested. Check electrical operation before changing valve settings.

Test that the correct solenoid is energised, by removing nut and raising solenoid slightly to feel pull.

Nominal Settings: Adjustments **7 & 9** approx. level with flange face. Two turns in either direction may then be necessary. Adjustments **6 & 8** turn all the way 'in' (clockwise), then 1.5 turns 'out' (c-clockwise). One final turn in either direction may be necessary.

6. Down Acceleration: When solenoids **C** and **D** are energised, the car will accelerate downwards according to the setting of adjustment **6**. 'In' (clockwise) provides a softer down acceleration, 'out' (c-clockwise) a quicker acceleration.

7. Down Speed: With solenoids **C** and **D** energised as in 6 above, the full down speed of the car is according to the setting of adjustment **7**. 'In' (clockwise) provides a slower down speed, 'out' (c-clockwise) a faster down speed.

8. Down Deceleration: When solenoid **C** is de-energised whilst solenoid **D** remains energised, the car will decelerate according to the setting of adjustment **8**. 'In' (clockwise) provides a softer deceleration, 'out' (c-clockwise) a quicker deceleration. **Attention: Do not close all the way in! Closing adjustment 8 completely (clockwise) may cause the car to fall on the buffers.**

9. Down Levelling: With solenoid **C** de-energised and solenoid **D** energised as in 8 above, the car will proceed at its down levelling speed according to the setting of adjustment **9**. 'In' (clockwise) provides a slower, 'out' (c-clockwise) a faster down levelling speed.

Down Stop: When solenoid **D** is de-energised with solenoid **C** remaining de-energised, the car will stop according to the setting of adjustment **8** and no further adjustment will be required.

KS Slack Rope Valve: Both solenoids **C** and **D** must be de-energised beforehand! Loosen the small grub screw on the top of the **K** on the left hand side. The **KS** is adjusted with a 3 mm Allen Key by turning the screw **K** 'in' for higher pressure and 'out' for lower pressure. With **K** turned all the way 'in', then half a turn back out, the unloaded car should descend when Manual Lowering **H** is opened. Should the car not descend, **K** must be backed off until the car just begins to descend, then backed off a further half turn to ensure that with cold oil, the car can be lowered as required.

Positions of Adjustments



Important: Length of $\frac{3}{4}$ " thread on pump connections should not be longer than 14 mm!

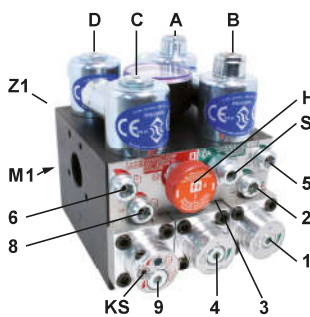

M1 Test pressure gauge connection, $\frac{1}{2}$ "

Z1 Pressure switch connection, $\frac{1}{4}$ "

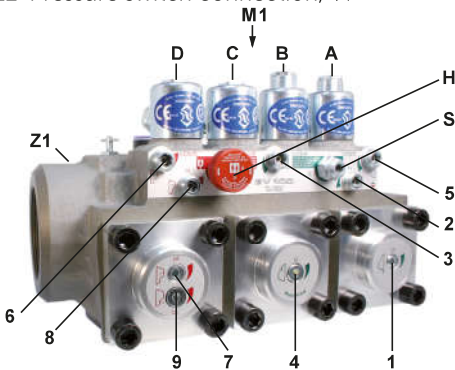

Adjustments UP

- 1 By Pass
- 2 Up Acceleration
- 3 Up Deceleration
- 4 Up Levelling Speed
- 5 Up Stop

Adjustments DOWN

- 6 Down Acceleration
- 7 Down Full Speed
- 8 Down Deceleration
- 9 Down Levelling Speed

Valve Types

- EV 0
- EV 1
- EV 10
- EV 100

Elements Omitted

- A, B, W, 3, 4 & 5
- B, W, 3 & 4
- A & 5
- as shown

Control Elements

- A Solenoid (Up Stop)
- B Solenoid (Up Deceleration)
- C Solenoid (Down Deceleration)
- D Solenoid (Down Stop)
- H Manual Lowering
- S Relief Valve
- U By Pass Valve
- V Check Valve
- W Levelling Valve (Up)
- X Full Speed Valve (Down)
- Y Levelling Valve (Down)

EV 100 $1\frac{1}{2}$ ", 2", 2 $\frac{1}{2}$ "

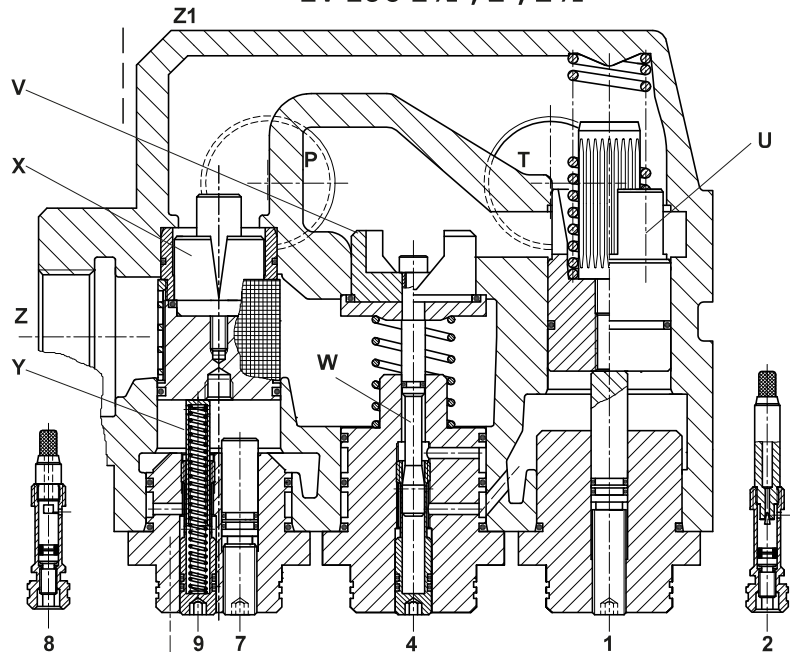

Horizontal Sections

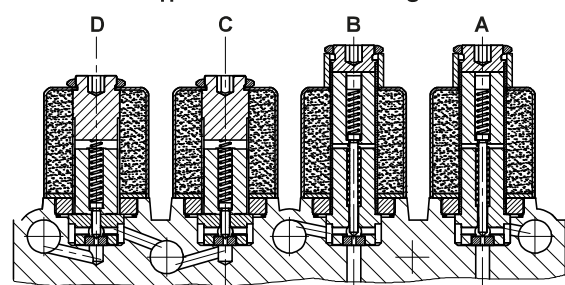
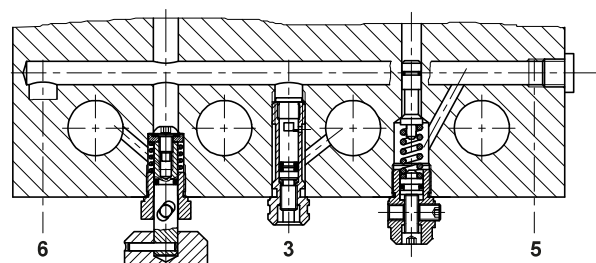

Vertical Section



Control Elements

- | | |
|---------------------------------------|----------------------------------|
| A Solenoid (Up Stop) | U By Pass Valve |
| B Solenoid (Up Deceleration) | V Check Valve |
| C Solenoid (Down Deceleration) | W Levelling Valve (Up) |
| D Solenoid (Down Stop) | X Full Speed Valve (Down) |
| H Manual Lowering | Y Levelling Valve (Down) |
| S Relief Valve | F Filter |

Adjustments UP

- 1** By Pass
- 2** Up Acceleration
- 3** Up Deceleration
- 4** Up Levelling Speed
- 5** Up Stop

Adjustments DOWN

- 6** Down Acceleration
- 7** Down Full Speed
- 8** Down Deceleration
- 9** Down Levelling Speed

Hydraulic Circuit

Electrical Sequence

EV 0

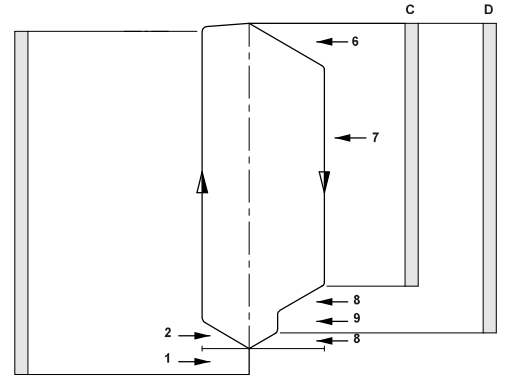
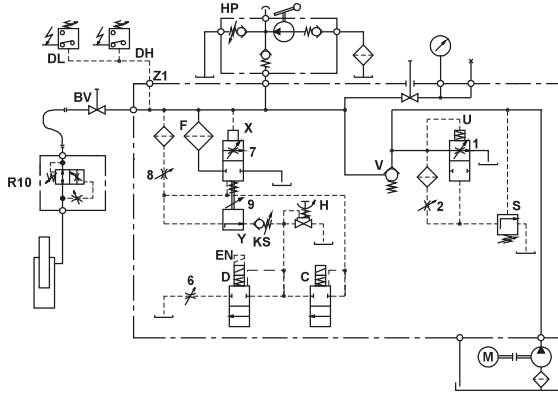

EV 1

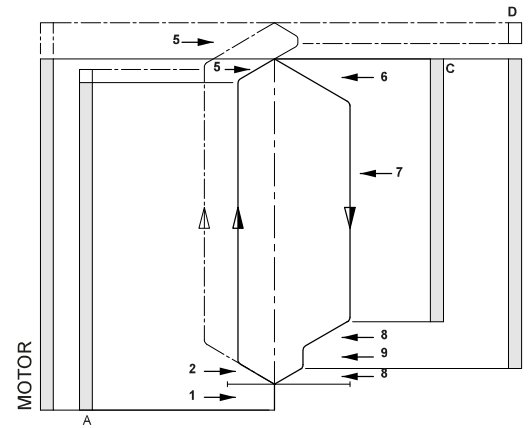
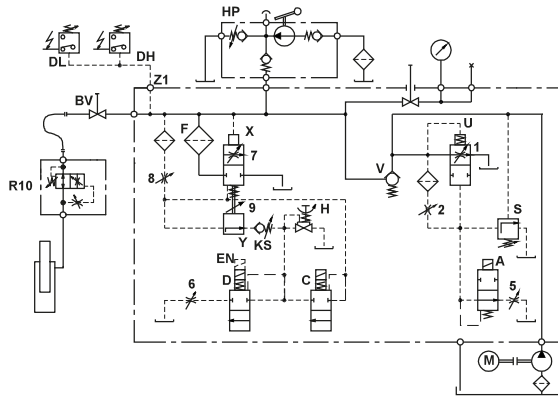

EV 10

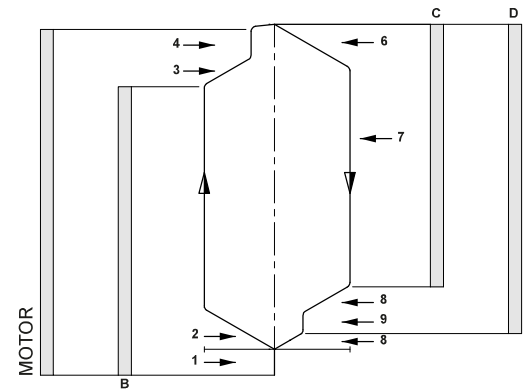
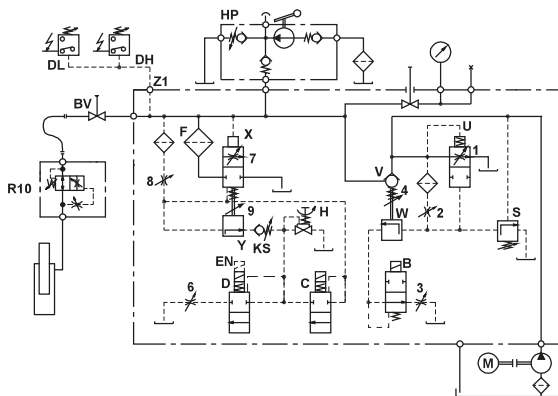

EV 100

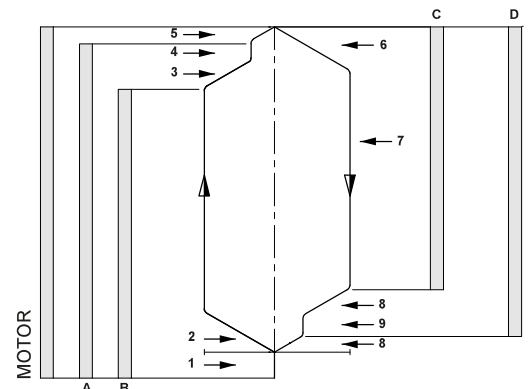
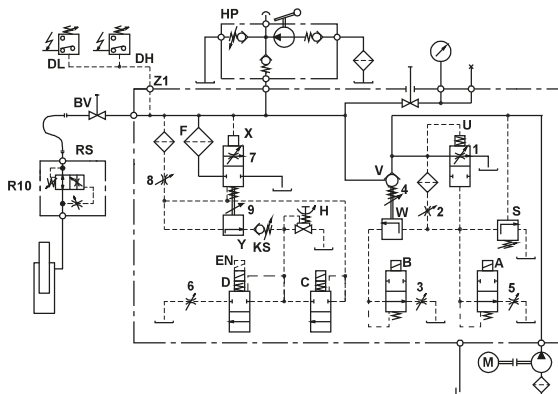



Pos.	No.	Item
1	FS	Lock Screw - Flange
	FO	O-Ring - Flange
	1F	Flange - By Pass
	EO	O-Ring - Adjustment
	1E	Adjustment - By Pass
	UO	O-Ring - By Pass Valve
	U	By Pass Valve
	UD	Noise Suppressor
	UF	Spring - By Pass
	2	2
3	3	Adjustment - Up Deceleration
4	EO	O-Ring - Adjustment
	4E	Adjustment - Up Levelling
	4F	Flange - Check Valve
	FO	O-Ring - Flange
	VF	Spring - Check Valve
	W	Up-Levelling Valve
	WO	O-Ring - Up Levelling Valve
	VO	Seal - Check Valve
	V	Check Valve
	W6	Screw - Check Valve
5	3	Adjustment - Up Stop
6	3	Adjustment - Down Acceleration
7	7F	Flange - Down Valve
	FO	O-Ring - Flange
	7O	O-Ring - Adjustment
	7E	Adjustment - Down Valve
	UO	O-Ring - Down Valve
	XO	Seal - Down Valve
	X	Down Valve
XD	Noise Suppressor	
F	Main Filter	
8	8	Adjustment - Down Deceleration
9E	Adjustment - Down Levelling	
9	EO	O-Ring - Adjustment
	9F	Spring - Down Valve
Y	Down Levelling Valve	
H	H	Manual Lowering - Self Closing
HO	HO	Seal - Manual Lowering
S	SE	Adjustment - Screw
	SM	Hexagonal
	MS	Grub Screw
	SO	O-Ring - Nipple
	SZ	Nipple
A+B	MM	Nut - Solenoid
	AD	Collar - Solenoid
	M	Coil - Solenoid (indicate voltage)
	AR	Tube - Solenoid 'Up'
	MO	O-Ring - Solenoid
	AN	Needle - 'Up'
	AF	Spring - Solenoid 'Up'
AH	Seat Housing - 'Up'	
AS	Seat - Solenoid 'Up'	
C+D	MM	Nut - Solenoid
	M	Coil - Solenoid (indicate voltage)
	DR	Tube - Solenoid 'Down'
	MO	O-Ring - Solenoid
	DF	Spring - Solenoid 'Down'
	DN	Needle - 'Down'
	DK	Core - Solenoid
DG	Seat Housing with Screen-'Down'	
FD	Filter Solenoid	
DS	Seat - Solenoid 'Down'	

No.	O-Ring-Size		
	3/4"	1 1/2"	2 1/2"
FO	26x2P	47x2.5P	58x3P *
EO	9x2P	9x2P	9x2P
UO	26x2V	39.34x2.62V	58x3V
WO	5.28x1.78V	5.28x1.78V	5.28x1.78V
VO	23x2.5V	42x3V	60x3V **
7O	5.28x1.78P	9x2P	9x2P
XO	13x2V	30x3V	47x3V
HO	5.28x1.78V	5.28x1.78V	5.28x1.78V
SO	5.28x1.78P	5.28x1.78P	5.28x1.78P
MO	26x2P	26x2P	26x2P

* FO by 4F 2 1/2" is 67x2.5P
** 90 Shore

O-ring: V = FKM - Viton
P = NBR - Perbunan

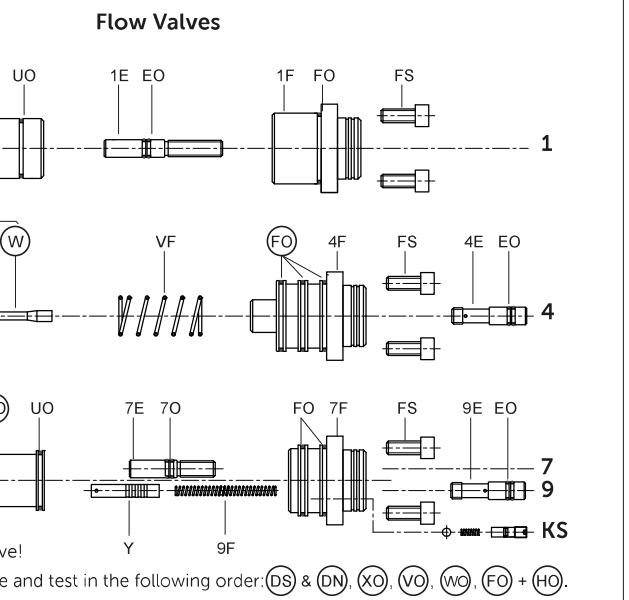
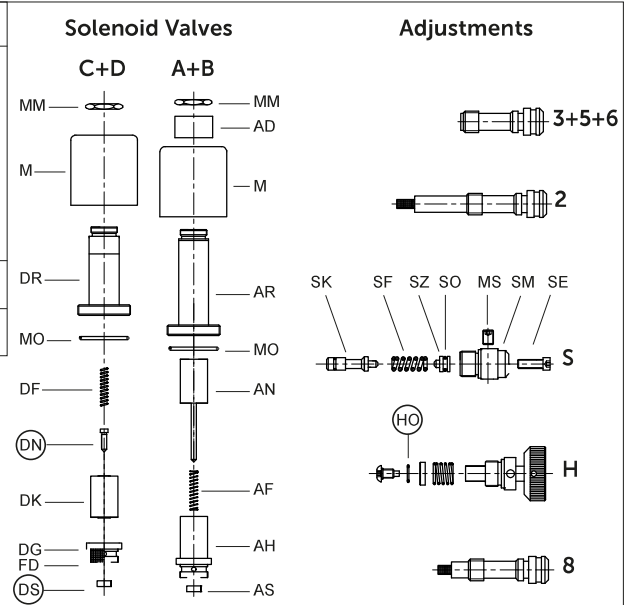

⚠ Taper threads: Do not exceed 8 turns of piping into the valve connections.

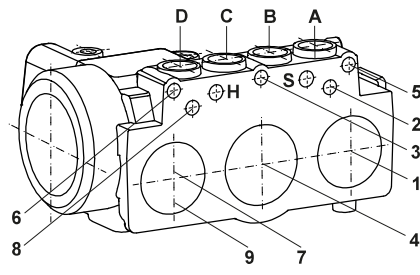
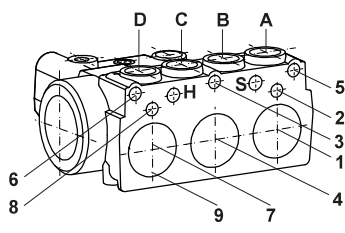
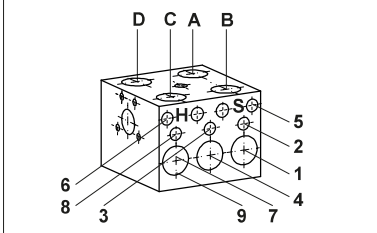

Flow Guide Selection Charts for Down Direction

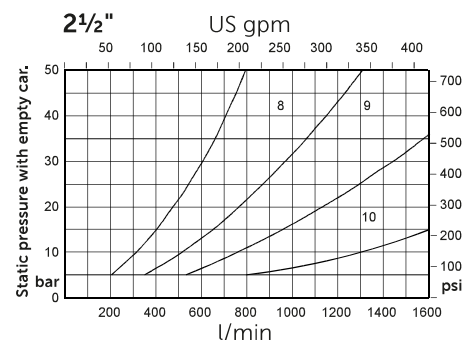
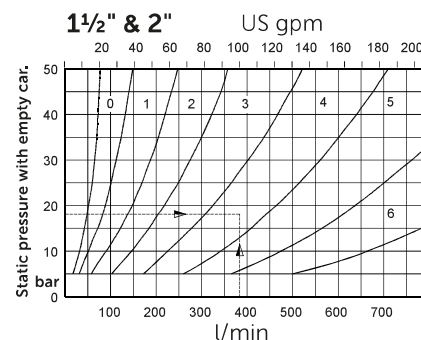
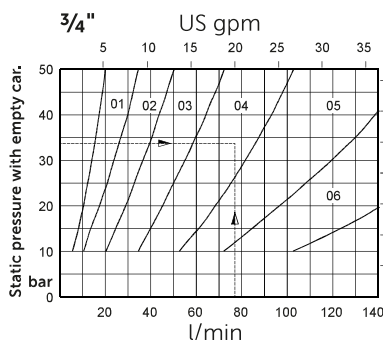

To order EV: Valve size (inch), valve type, state pump flow, empty car pressure (or flow guide size) and solenoid voltage.

Example order: 2"EV100, 380l/min, 18bar (empty), 110 AC or 2"EV100/4/110AC